

ES-Projektseminar WS16

Abschlusspräsentation



TECHNISCHE
UNIVERSITÄT
DARMSTADT

Team Mephobia: Jonas Gehringer, Manishkumar Jain, Jan-Christoph Klie, Matthias Klimmek, Mario Wetzel

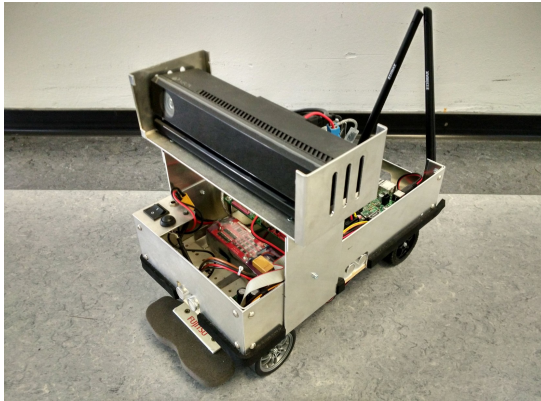

Das Team



Jonas Gehringer



Manishkumar Jain



Jan-Christoph Klie



Matthias Klimmek



Mario Wetzel

Rundkurs ohne Hindernisse

Lösungsidee

- ▶ ROS Navigation Stack für Wegplanung
- ▶ Ecken durch Kinect erkennen und dann abbiegen

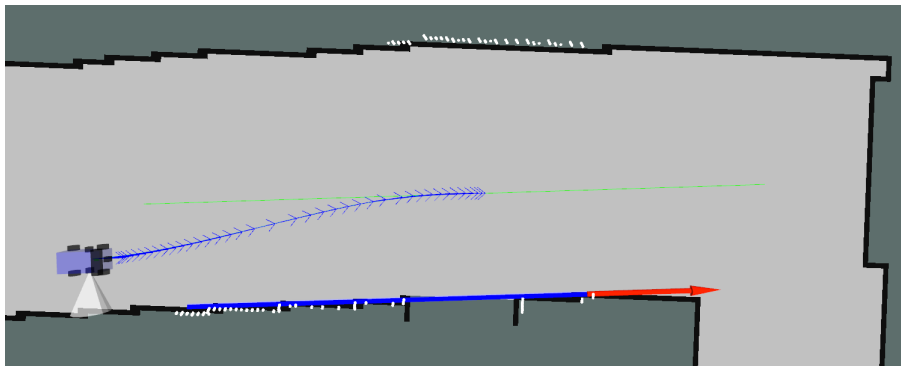

Rundkurs ohne Hindernisse

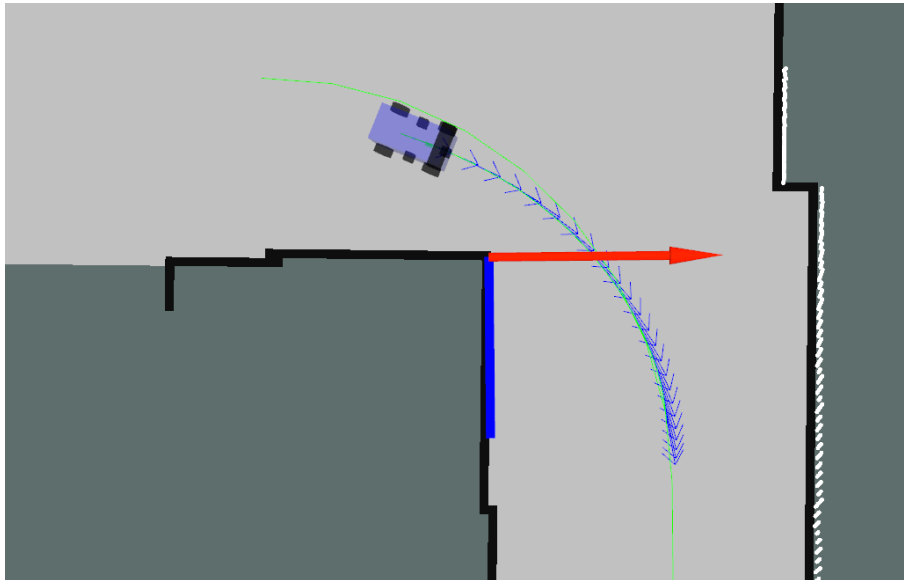

Video Rundkurs

Rundkurs ohne Hindernisse

Vorteile

- ▶ Controller kann an offenen Türen vorbeifahren
- ▶ Benötigt keine Karte
- ▶ Geschwindkeitsregelung durch Trajektorienplanung

Nachteile

- ▶ Abhängig von der Qualität des Laserscans
- ▶ Störanfälliger (besonders am Anfang)

Kinect

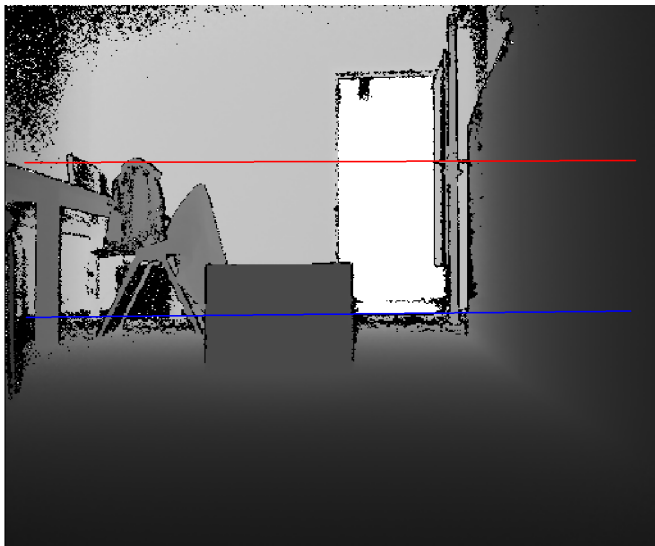

Rundkurs mit Hindernissen - Ansatz

Ansatz

- ▶ Zwei Laserscans für separates Erkennen von Wänden und Hindernissen
- ▶ Wiederverwendung des Ansatzes vom Rundkurs ohne Hindernisse
- ▶ Hindernisse werden in Costmap eingetragen
- ▶ Local Planner plant Pfad zum Ausweichen

Rundkurs mit Hindernissen

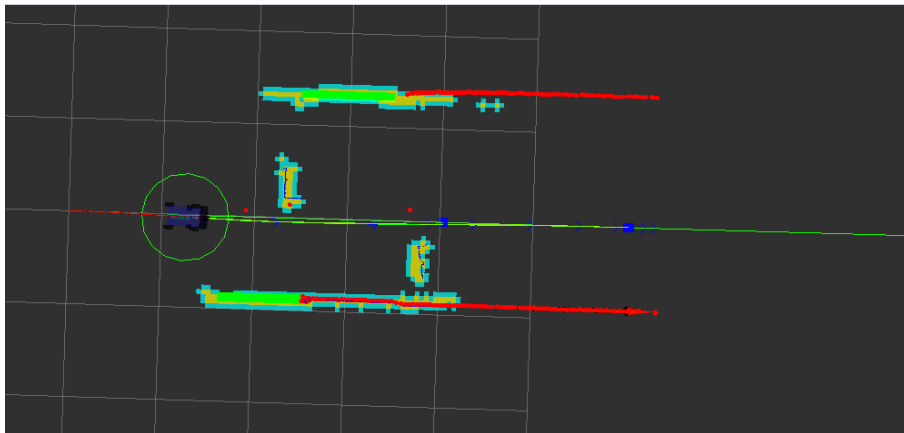

Live Demo

Line Following

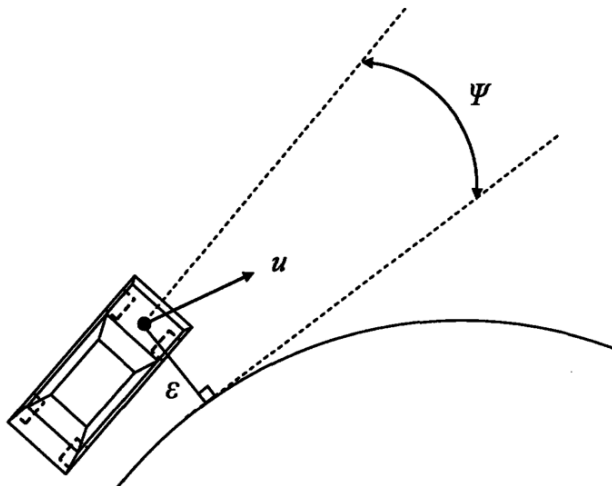



$$\delta(t) = \psi(t) + \tan^{-1} \frac{k\epsilon(t)}{u(t)}$$

Reflexion - Zeit/Projektplanung

 **Mephobia**

 Boards

 Members

 Settings

Controller

Line following

**Lowlevel - Sensor
and Hardware**

**Project
management**

**Rundstrecke mit
Hindernissen**

**Rundstrecke ohne
Hindernisse**

Reflexion - Zeit/Projektplanung

The screenshot shows a Trello board for 'Project management' with a purple header. The board is organized into four columns: 'Deadlines', 'To Do', 'Doing', and 'Done'. The 'Deadlines' column lists 'Live-Demo competition' (due Feb 28), 'Final presentation' (due Mar 3), and 'Documentation and Report' (due Mar 3). The 'To Do' column is currently empty. The 'Doing' column contains 'Clean up and comment code; merge redundant parts' and 'Abschlussbericht schreiben' (due Mar 2, 2/7 progress, assigned to JK, JG, MJ, MK). The 'Done' column lists 'Test Laptop remote control', 'Slides for first presentation', 'Slides for last presentation', 'Schedule (Bi-)weekly Meeting with Geza', 'Clarify Roles', 'Meet Geza', and 'Choose Tasks'. The board is shared with 'Jan-Christoph Klie' and is visible to the team.

Boards **JK** Jan-Christoph Klie

Project management Mephobia Team Visible Subscribed Show Menu

Deadlines ...

- Live-Demo competition Feb 28
- Final presentation Mar 3
- Documentation and Report Mar 3

Add a card...

To Do ...

Add a card...

Doing ...

- Clean up and comment code; merge redundant parts
- Abschlussbericht schreiben Mar 2 1 2/7

Add a card...

Done ...

- Test Laptop remote control 1
- Slides for first presentation
- Slides for last presentation
- Schedule (Bi-)weekly Meeting with Geza
- Clarify Roles
- Meet Geza
- Choose Tasks 1

Add a card...

Reflexion - Hardwareprobleme

- ▶ Unzuverlässige Odometrie bei kleinen Geschwindigkeiten
- ▶ Crash des uC-Boards erfordert vollständigen Neustart des SoC
- ▶ Qualität der Kinect-Daten schwankt stark mit wechselnden Lichtverhältnissen

Danke für die Aufmerksamkeit

Fragen?